

ECO 3624

Distributed By:



2717 Tobey • Indianapolis, IN 46219
(317) 545-0665 • FAX (317) 545-0670 • (800) 800-0665
www.idsblast.com



WARNING

DO NOT USE *SAND*. SAND WILL CAUSE SILICA DUST, WHICH IS THE CAUSE OF SILICOSIS, A CONDITION OF MASSIVE FIBROSIS OF THE LUNGS. *THIS STATEMENT INDICATES POTENTIAL PERSONNEL HAZARD. FAILURE TO COMPLY WITH THESE INSTRUCTIONS MAY RESULT IN PERSONAL INJURY.*

WEBSITE FOR SILICOSIS:

<http://www.osha.gov/Silica/IT69DI.html>

SET-UP INSTRUCTIONS

OPTIONAL

FOOT CONTROL & AIR CONTROLS (21 CFM MINIMUM) SEE DRAWING (M7056)

- 1. Remove box from machine with Hand Gun and Air Controls.**
- 2. Attach regulator bracket (item 4 to front of cabinet).**
- 3. Connect regulator to bracket with lock ring.**
- 4. Connect compressed air hose to inlet side of regulator.**
- 5. Connect air hose from foot control to left side of cabinet.**
- 6. Connect media hose to pick-up tube under grate.**
- 7. Attach snap-in gloves to arm hole opening. Work snap ring into hole, one ring in front of opening and one ring behind hole.**
- 8. Attach dust collector to left side of cabinet with supplied hardware.**
- 9. Plug DC cord into cord from light assembly.**

ECO 12 & 21 CFM TRIGGER GUN SEE DRAWING (A9078)

- 1. Remove box from machine with Hand Gun and Components.**
- 2. Connect compressed air hose to the left front side of the cabinet.**
- 3. Connect media hose to pick-up tube.**
- 4. Mount the media pick-up tube at the bottom of the left sump.**
- 5. Connect compressed air supply to the fitting on the left front side of the cabinet.**
- 6. Attach snap-in gloves to arm hole opening. Work snap ring into hole, one ring in front of opening and one ring behind hole.**
- 7. Attach dust collector to left side of cabinet with supplied hardware.**
- 8. Plug DC cord into cord from light assembly.**

UNPACKING AND ASSEMBLY

MACHINES WITH CARTRIDGE TYPE DUST COLLECTOR

- 1. Remove all shipping protection:** Plastic wrapping, shipping pallet, box's inside, etc. Check for any concealed shipping damage, if discovered, report the damage to your freight carrier immediately.
- 2. Blast Cabinet should be placed in a desired location, away from any water or liquid environment such as cleaning vats, etc., where the air supply is not restricted and dry. If moist compressed air is present at this location, install a good moisture separator.**
- 3. Installing Dust Collector:**

Apply putty tape to cabinet around large hole, press to make a firm bond to cabinet and squeeze together at seam. Align the 4 hole bolt pattern and install bolts, washers, and nuts. Tighten bolts and nuts securely to seal around putty tape. Plug electrical cord from side of dust collector into plug from light box.

- 4. Connect the electrical cord from light box grounded electrical source, 110V/60 cycle, single phase**

CHARGING WITH BLAST MEDIA

- 5. Charge blast machine with abrasive. GLASS BEADS / ALUMINUM OXIDE Pour media into cabinet through one of doors, fill to ½ UP THE PICK-UP TUBE.**

WARNING NEVER USE SAND AS A BLAST MEDIA

SEE WARNING ON COVER PAGE

PREPARING PARTS FOR BLASTING

- 1. Preparing parts for blasting: all parts to be processed must be free of oil, grease and moisture. Make sure parts are dry before putting into cabinet for cleaning.**
- 2. Air Pressure: 5 PSI to 80 PSI set air pressure at 80 PSIG. Most parts for blast cleaning can be blasted at 80 PSI. Designate parts to be processed, start at lower pressure and work up the PSI scale to obtain desired finish.**
- 3. Gun Angle and Distance: Direct blast at part with and approximate (45-60) degree angle with ricochet toward the back side of cabinet. Do not hold gun at 90 degree to part being processed. This will cause the media blast to bounce back into the blast stream and slow blasting action. Also 90 degree angle will cause excessive wear on gun and viewing window. Hold gun approximately 6 inches from part being cleaned.**
- 4. Media: Media should be of good quality and dry. Damp media will cause the media not to flow and will clog abrasive flow.**

*****NEVER USE SAND*****

See "WARNING" on COVER PAGE

If you are having a problem selecting media for a specified job, contact your distributor for their recommendations.

TROUBLESHOOTING

- 1. Blasting Gun: After 10-12 hours of blasting time the air orifice and nozzle should be checked. If the nozzle shows wear, rotate ¼ turn to prevent uneven wear. If this is not checked, it could result in destruction of nozzle and damage to the gun housing. If wear is detected on the orifice tip, replace it.**
- 2. Caking of Media:**
 - A. Media caking is caused by moisture in compressed air supply of oily and greasy parts. If this is not corrected, media will not flow and will clog gun. Check air supply. If water or moisture is present, install a good moisture trap. If oily or greasy parts are being blast treated, you should first degrease and dry parts.**
 - B. If blast gun should occasionally clog, place thumb over nozzle (hold tight) and pull trigger 3 to 4 seconds. This will cause the system to back blast through the gun media hose and clear media hose.**
- 3. Gun Air Pressure Drop: Set air regulator at 80 PSI on air gauge. A restriction in the supply line such as reducers or quick couplers will cause pressure drop. Also, if the blast cabinet is too far from the air compressor, a pressure drop can occur. We recommend ½"- 1" I.D. air supply line**
- 4. Poor Visibility – Excessive Dust:**
 - A. Cabinet air inlet blocked, check for blockage.**
 - B. Dust collector sump full and needs emptying.**
 - C. Cartridge contaminated. Clean by pushing up and down.**
 - D. Media breakdown – replace media.**
- 5. Poor Media Flow:**
 - A. Wet or damp media caused from moisture or oil in compressed air line.**
 - B. Use dry air or install moisture filter.**
 - C. Replace media and clean media sump hose.**
 - D. Hole in media hose from wear, replace hose assembly.**
 - E. Air orifice assembly in gun worn, replace assembly.**

**DO NOT OPEN ANY OF THE DOORS
WHEN MACHINE IS IN OPERATION.**

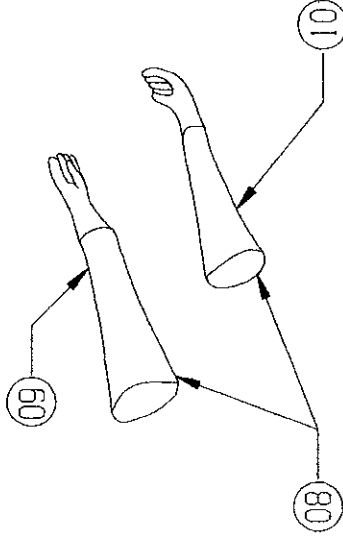
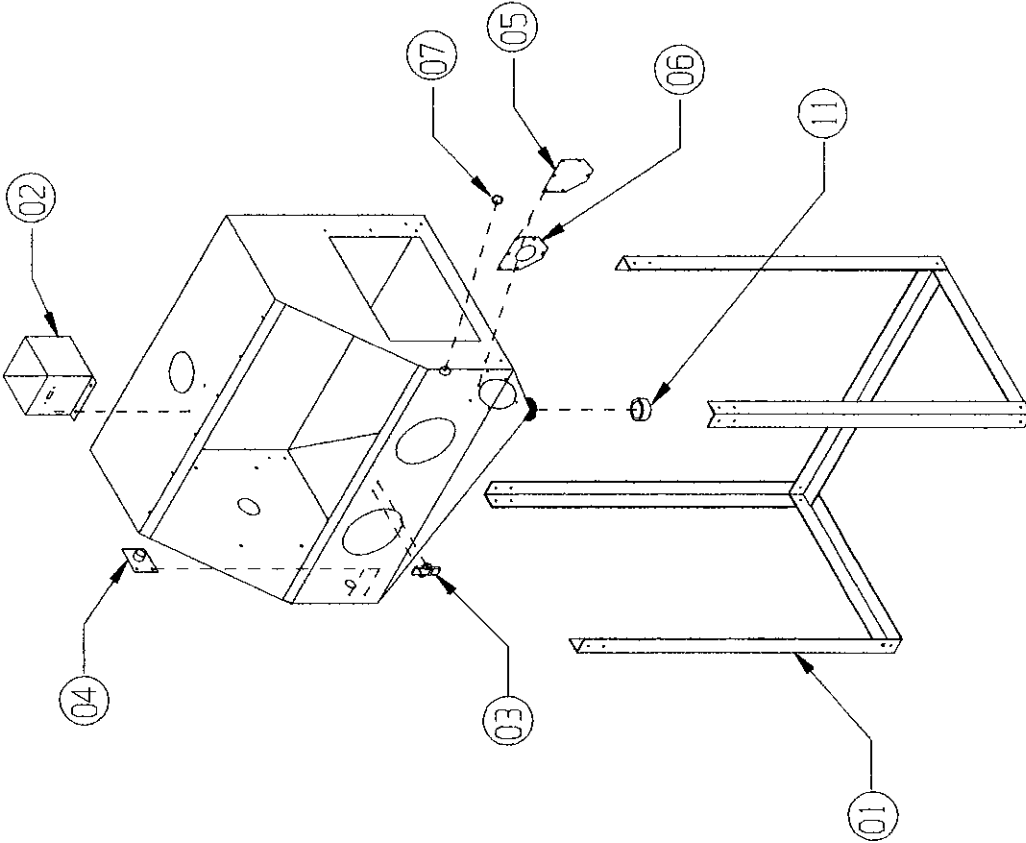

11	1	2" CAP PLUG	010212
10	1	RIGHT SNAP IN GLOVE	22-112
09	1	LEFT SNAP IN GLOVE	22-111
08	1	SNAP IN GLOVES (PR.)	22-110
07	1	HOLE PLUG, 1 3/16"	13-645
06	1	HOSE ADAPTOR	A590
05	1	SUMP COVER PLATE	D105-17
04	1	AIR FITTING	A747-04
03	1	FRONT DOOR LATCH	011205
02	1	LIGHT BOX ASSEMBLY	SEE DWG. M151
01	1	LEG ASSEMBLY	SEE DWG. M154
ITEM NO.	QTY.	DESCRIPTION	DWG. NO. / MATERIAL

LARRY HESS & ASSOCIATES, INC.
SALISBURY NORTH CAROLINA

DESCRIPTION: ECD 3624

MATERIAL:

CONFIDENTIAL

THE DISCLOSURES AND CONTENTS OF THIS DRAWING ARE CONFIDENTIAL AND ARE THE EXCLUSIVE PROPERTY OF BLAST-IT-ALL® A DIV. OF LARRY HESS & ASSOCIATES, INC. THIS DRAWING IS NOT TO BE COPIED OR REPRODUCED WHOLLY OR IN PART WITHOUT WRITTEN PERMISSION OF LARRY HESS & ASSOCIATES, INC.

DATE:	DATE:	SCALE:	JOB NO.:
LJF	06/12/02	3/64" = 1"	
DATE:	DATE:	FRACTIONAL:	STD.
		DECIMAL:	
		ASSEMBLY:	NOT ASY.:

DRAWING NO.:

A748

REV.	DESCRIPTION	BY	DATE

STANDARD MACHINE

M152

MODEL : ECO 3624

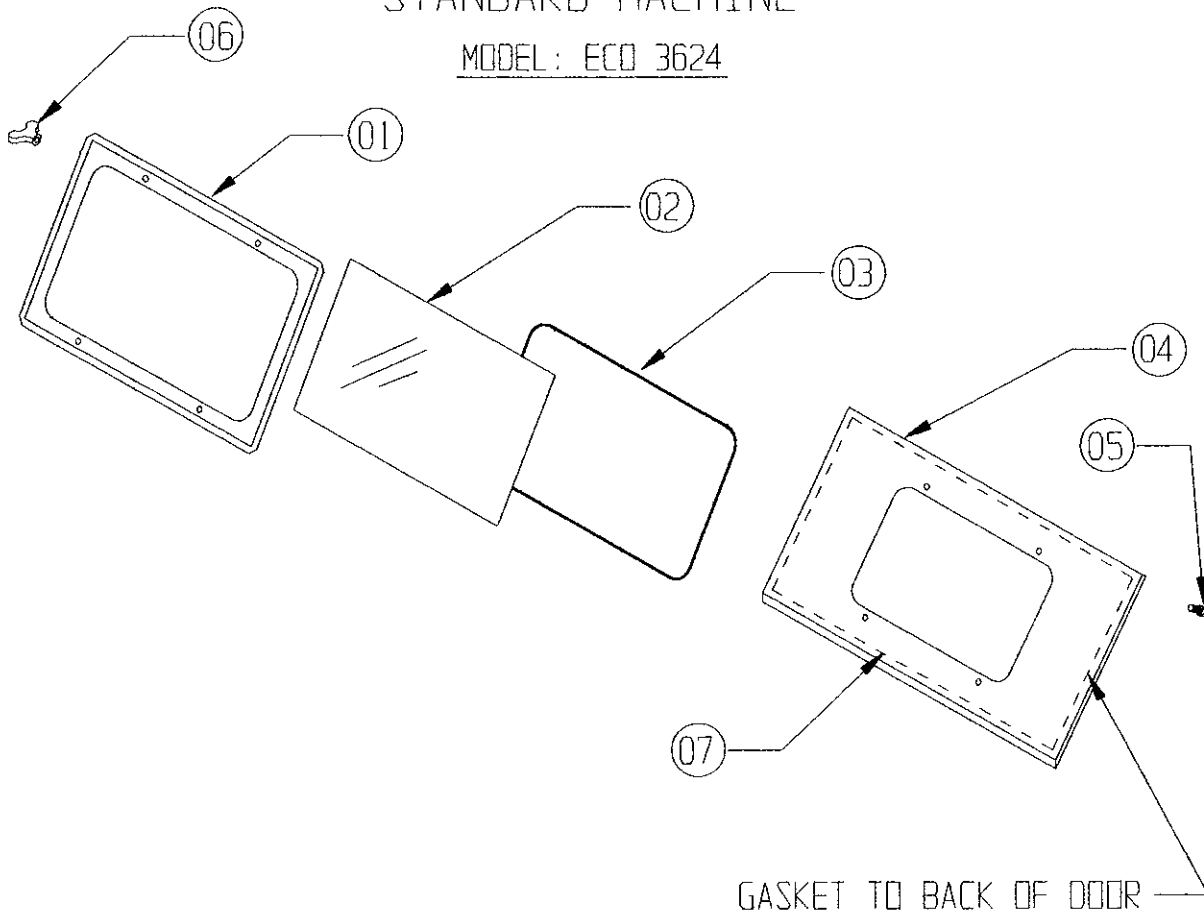

ITEM NO.	QTY.	DESCRIPTION	PART NO.
01	1	WINDOW FRAME	23-053
02	1	WINDOW, VIEWING	23-050
03	1	WINDOW GASKET (75")	24-054
04	1	FRONT DOOR	A745
05	4	1/4-20 x 1 ROLOX	30-148
06	4	1/4-20 WING NUT	30-510
07	1	DOOR GASKET (112")	24-054

STANDARD MACHINE

M155

SIDE DOOR

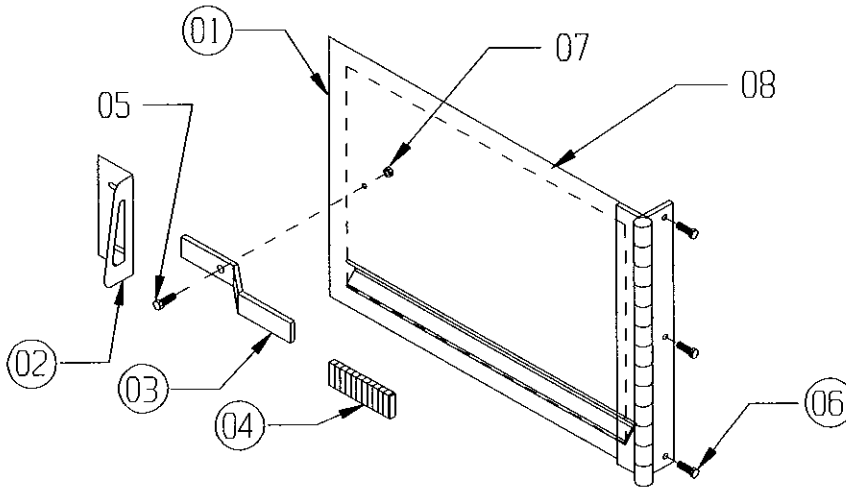

ITEM NO.	QTY.	DESCRIPTION	PART NO.
01	1	SIDE DOOR	A755
02	1	LATCH, DOOR	15-718
03	1	CAM, DOOR	15-719
04	1	DOOR CAM RUBBER GRIP	15-720
05	1	1/4 x 1" BOLT	30-106
06	3	10-24 x 1/2 SCREW	30-101
07	1	1/4" NYLOCK NUT	30-503
08	1	DOOR GASKET (60")	24-054
09	3	10-24 NYLOCK NUTS	30-500

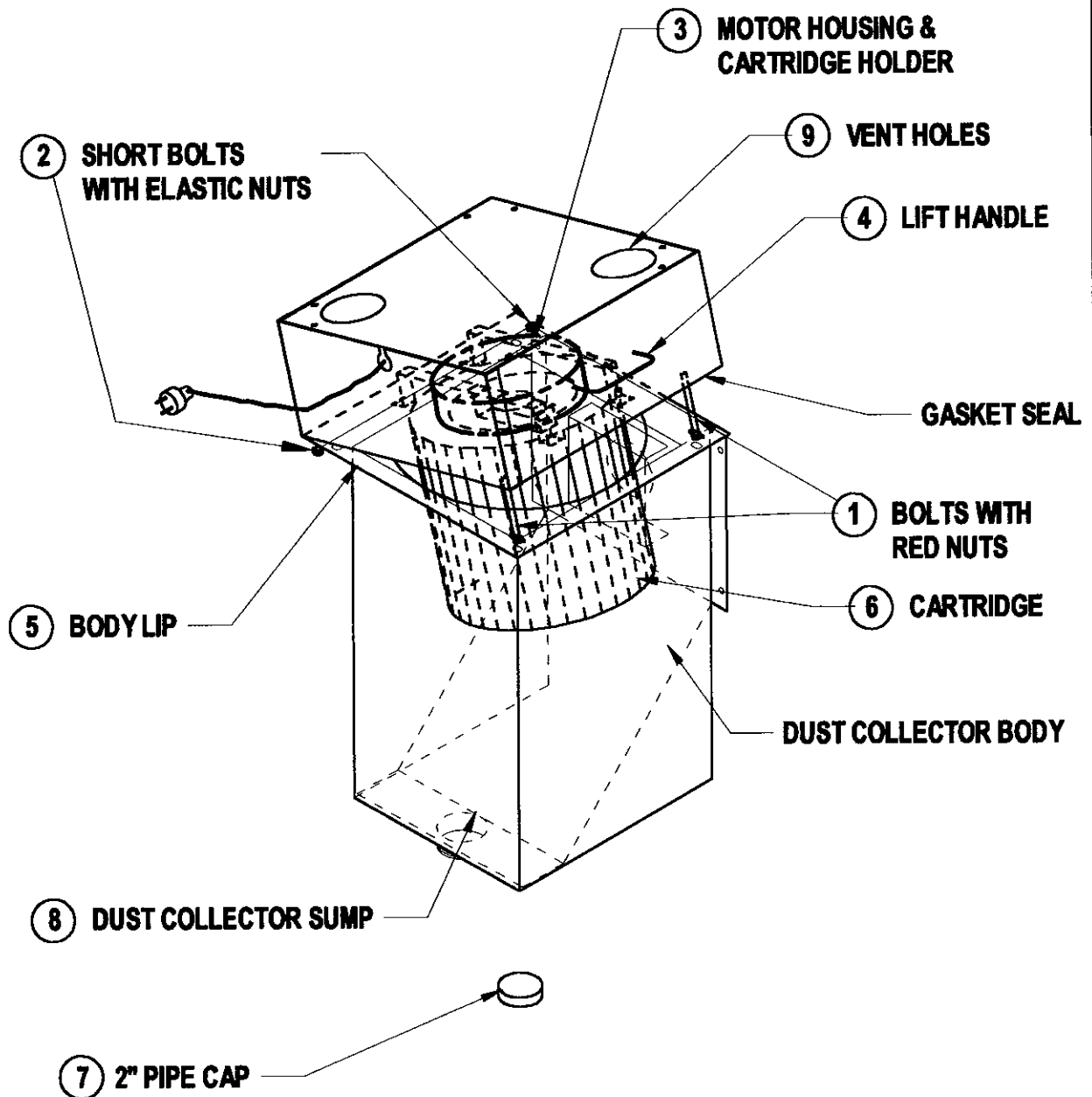

ITEM NO.	QTY.	DESCRIPTION
1	2	LONG BOLTS WITH NUTS
2	2	SHORT BOLTS WITH ELASTIC NUTS
3	1	MOTOR HOUSING & CARTRIDGE HOLDER
4	1	LIFT HANDLE
5	1	BODY LIP
6	1	CARTRIDGE
7	1	2" PIPE CAP
8	1	DUST COLLECTOR SUMP
9	2	VENTILATION HOLES

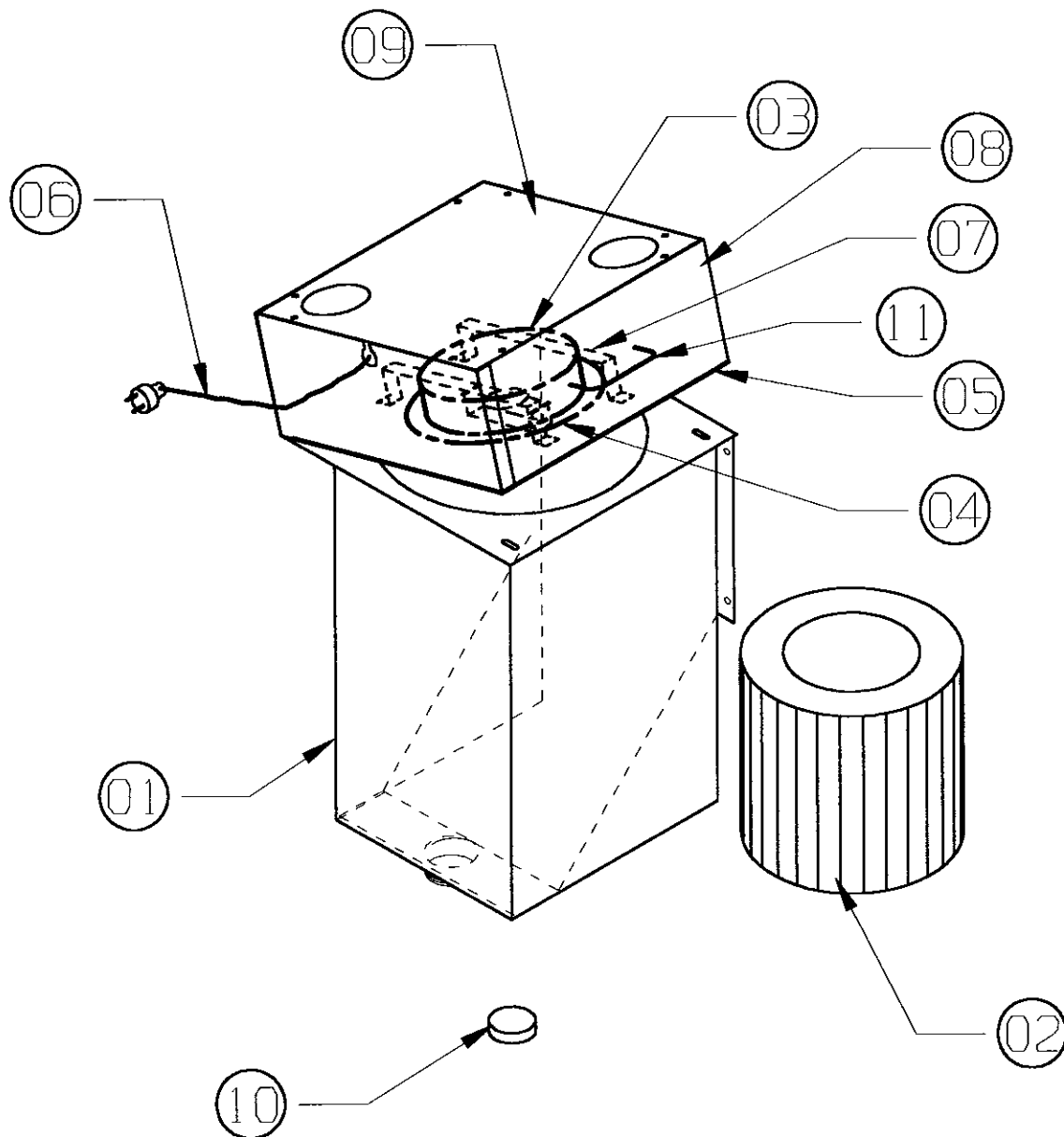

ITEM NO.	PART NO.	DESCRIPTION
1	009055	DUST COLLECTOR
2	11-1524	DUST COLLECTOR CARTRIDGE
3	13-200	MOTOR, 120V, 60/50 Hz, 6.9 AMP
4	24-056	GASKET, MOTOR SEAL
5	24-054	GASKET, TOP SEALING (52 1/2")
6	010172	CORD, MALE PLUG
7	D2025-09	MOTOR BRACKETS
8	D2025-05&06	MOTOR HOUSING
9	D2025-04	COVER PLATE
10	010212	2" PIPE CAP
11	-----	LIFT HANDLE

MACHINE AIR CONTROLS

M7053

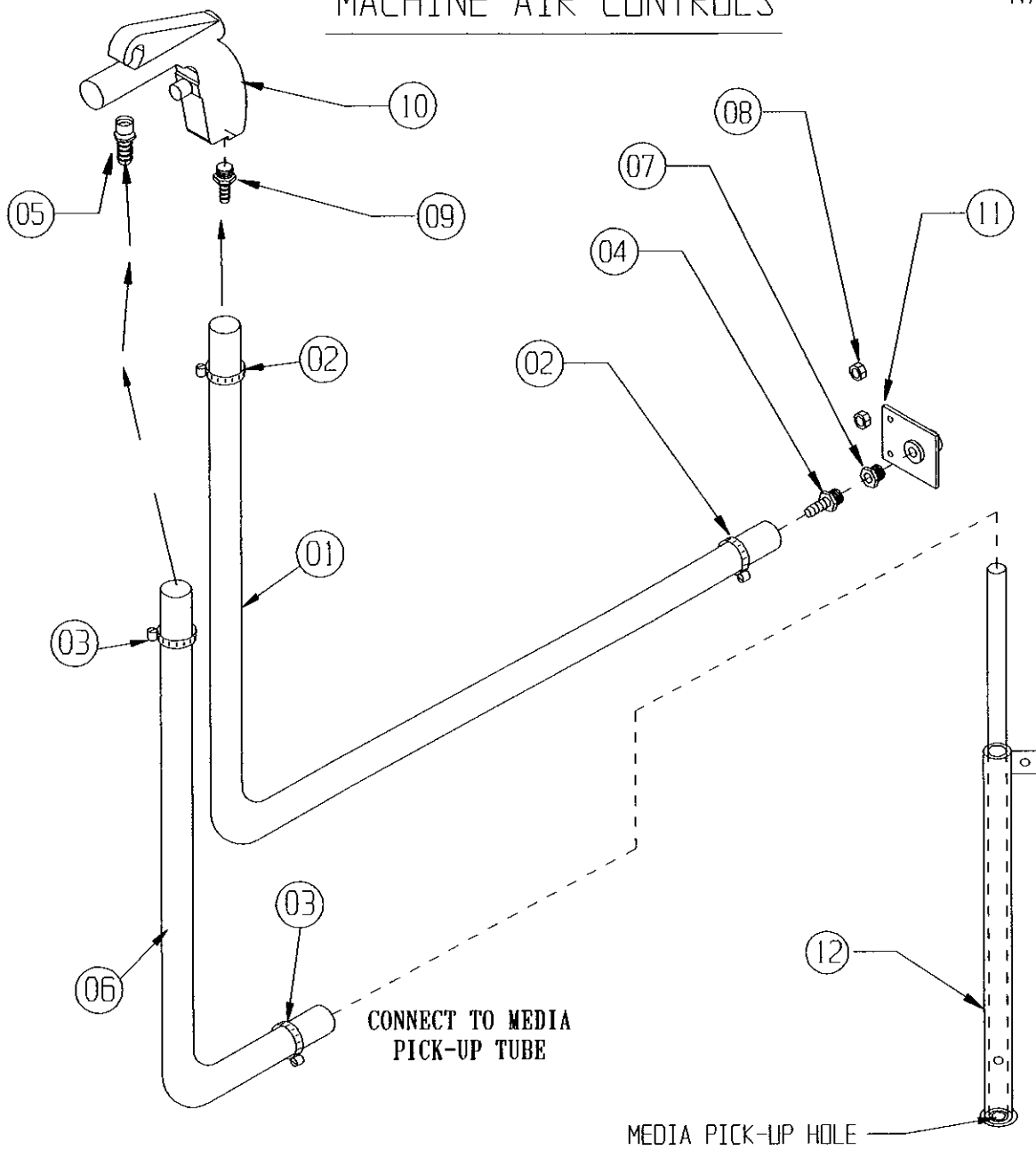

ITEM NO.	QTY.	DESCRIPTION	PART NO.
01	1	HOSE, 1/4" AIRLINE (3')	18-074
02	2	1/2" HOSE CLAMP	010412
03	2	1/4" HOSE CLAMP	010413
04	1	FITTING, 1/4" HOSE x 1/4" NPT	14-313
05	1	FITTING, 1/2" HOSE x 3/8" NPT	14-302
06	1	HOSE, MEDIA 1/2" (4 1/2')	18-076
07	1	1/2 x 1/4" BUSHING	14-441
08	2	1/4 x 24 STANDARD NUT	30-502
09	1	1/4 HOSE x 1/8" BARB FITTING	14-316
10	1	BLAST GUN	011642
11	1	AIR FITTING	A747-04
12	1	MEDIA PICK-UP TUBE	010464

A9078

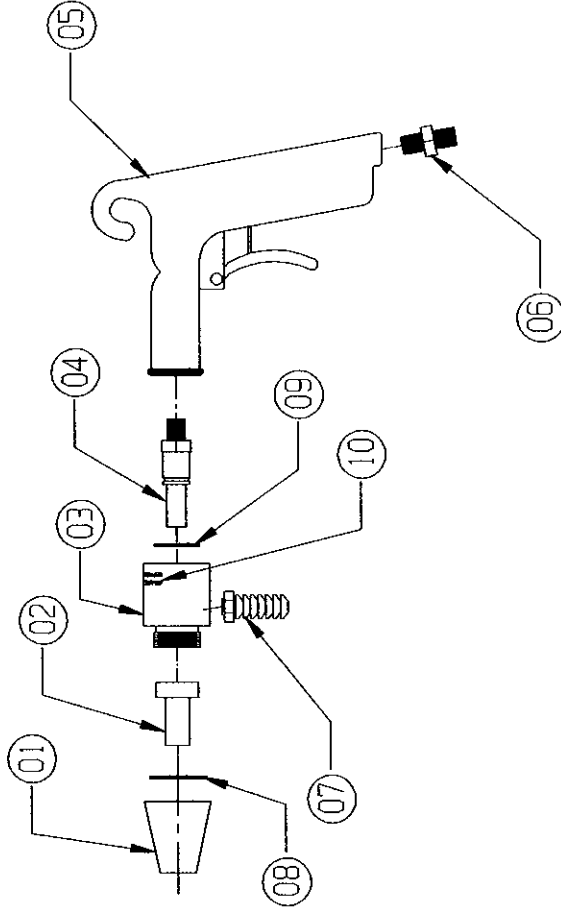

CONFIDENTIAL

THE DISCLOSURES AND CONTENTS OF THIS DRAWING ARE CONFIDENTIAL AND ARE THE EXCLUSIVE PROPERTY OF BLAST-IT-ALL® A DIV. OF LARRY HESS & ASSOCIATES, INC. THIS DRAWING IS NOT TO BE COPIED OR REPRODUCED WHOLLY OR IN PART WITHOUT WRITTEN PERMISSION OF LARRY HESS & ASSOCIATES, INC.

10	1	SET SCREW	011640-1
09	1	D-RING (SMALL)	011640-2
08	1	D-RING (LARGE)	20-053
07	1	FITTING 3/8MPT x 1/2 HOSE	14-302
06	1	FITTING 1/4MPT x 1/4 HOSE	14-313
05	1	GUN, HAND TRIGGER CONTROL W/END	011642
04	1	AIR JET 1/8 WITH O RING	011640
04	1	AIR JET 3/32 WITH O RING * STD.	011639
03	1	SUCTION BODY	011641
02	1	CARBIDE NOZZLE 5/16	011638
02	1	CARBIDE NOZZLE 1/4	011637
02	1	CERAMIC NOZZLE 5/16	011636
02	1	CERAMIC NOZZLE 1/4 * STD.	011635
01	1	NOZZLE ADAPTOR	011634
**		GUN WITH 5/16 CARBIDE NOZZLE	011633
**		GUN WITH 1/4 CARBIDE NOZZLE	011632
**		GUN WITH 5/16 CERAMIC NOZZLE	011631
**		GUN WITH 1/4 CERAMIC NOZZLE * STD.	011630

ITEM NO. QTY. DESCRIPTION DWG. NO. / MATERIAL

LARRY HESS & ASSOCIATES, INC.
SALTSBURY NORTH CAROLINA

DESCRIPTION: ECO-12 OR 21 CFM GUN

MATERIAL: PER DWG.

DATE: 01/04/01	SCALE: 1/4" = 1"	JOB NO: 16199
DATE:	REVISION: ESCAL.	REV. ASST.:
DATE:	REVISION:	REV. ASST.:

DRAWING NO.:

A9078

REV.	DESCRIPTION	BY	DATE

OPTIONAL FOOT CONTROL GUN
(21 CFM MINIMUM)

M7056

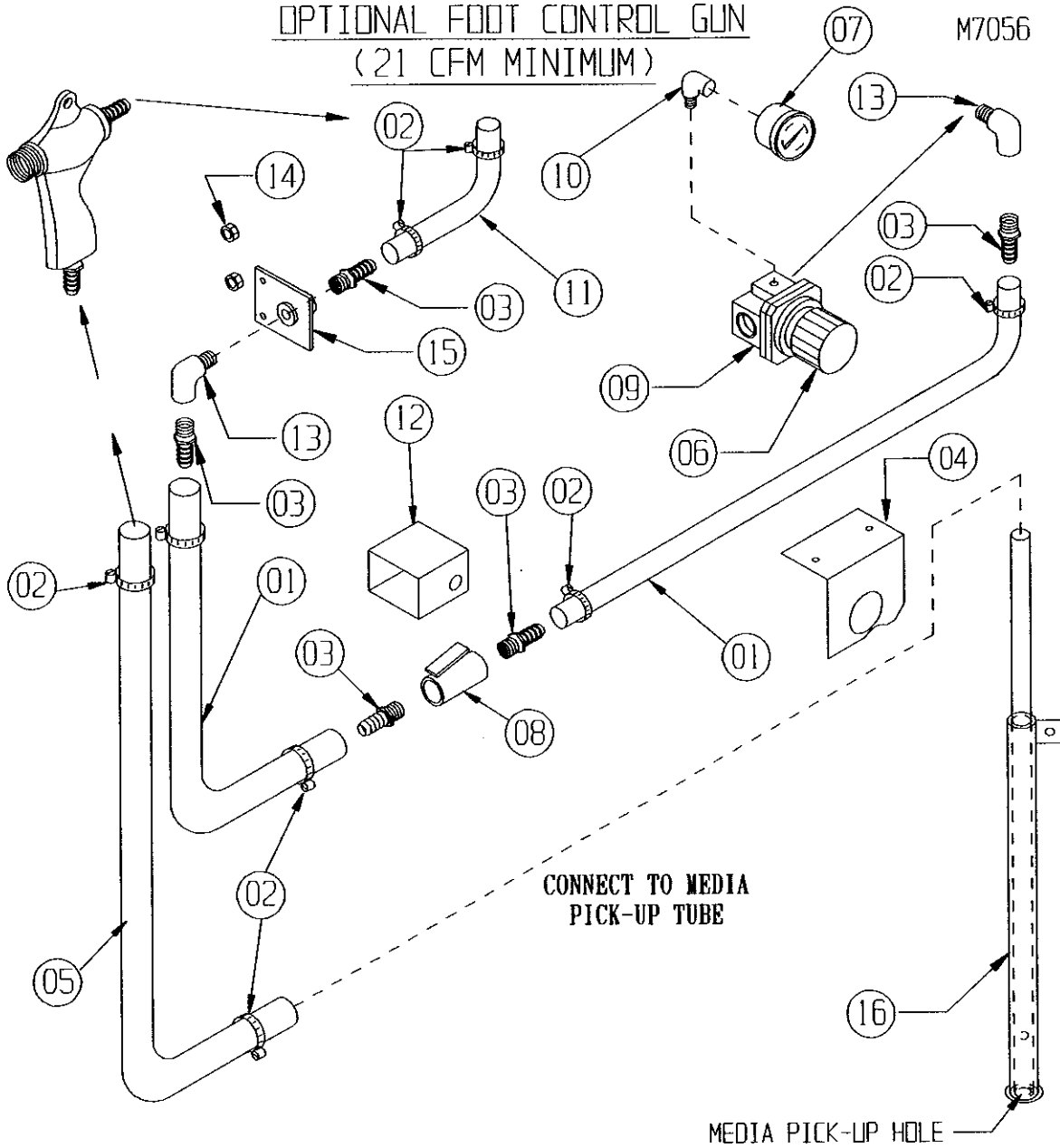

ITEM NO.	PART NO.	DESCRIPTION
1	18-076	HOSE, AIRLINE (6')
2	21-032	CLAMP, HOSE
3	14-301	FITTING, 1/2" HOSE x 1/2" MPT
4	D105-13	REGULATOR BRACKET
5	18-084	HOSE, MEDIA LINE (3')
6	16-965	REGULATOR, AIR 1/2"
7	16-820	GALGE, AIR
8	18-835	VALVE, AIR FOOT CONTROL ONLY
9	16-965LR	REGULATOR LOCK RING
10	14-524	1/4" STREET ELL
11	18-076	HOSE, AIRLINE (3')
12	16-836	HOUSING, FOOT CONTROL ONLY (NO SWITCH)
13	14-372	1/2" STREET ELL
14	30-502	1/4 x 24 STD. NUT
15	A747-04	AIR FITTING
16	010464	MEDIA PICK-UP TUBE

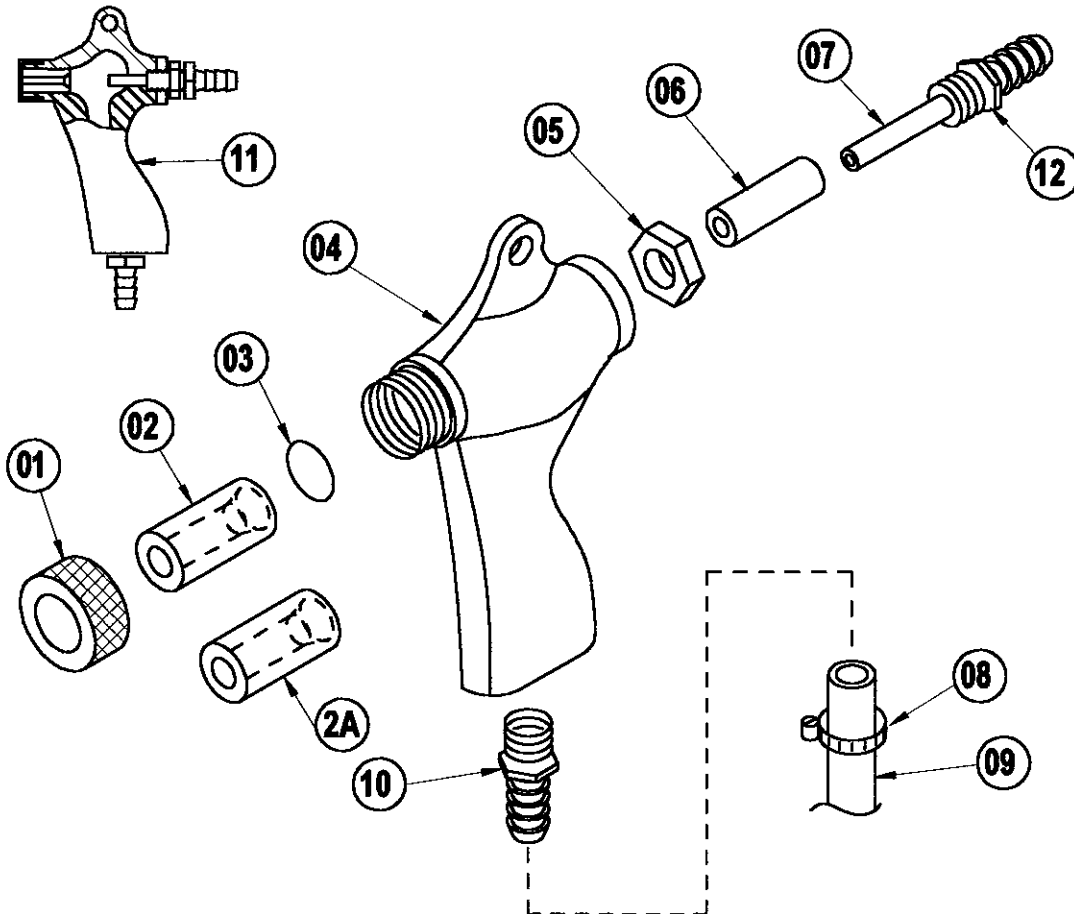

ITEM NO.	PART NO.	DESCRIPTION
1	20-054	NOZZLE NUT HOLDING
2	20-074	NOZZLE CERAMIC, 1/4" I.D. SIZE 4
2	20-075	NOZZLE CERAMIC, 5/16" I.D. SIZE 5
2	20-076	NOZZLE CERAMIC, 3/8" I.D. SIZE 6
2A	20-084	NOZZLE CARBIDE, 1/4" I.D. SIZE 4
2A	20-085	NOZZLE CARBIDE, 5/16" I.D. SIZE 5
2A	20-086	NOZZLE CARBIDE, 3/8" I.D. SIZE 6
3	20-053	"O" RING - NOZZLE SEALING
4	20-040	GUN BODY ONLY
5	20-052	LOCKNUT, ORIFICE
6	20-063	RUBBER COVER, ORIFICE
7	20-064	ORIFICE AIR 4/32" I.D. SIZE 4 INCLD. #6 & 7
7	20-065	ORIFICE AIR 5/32" I.D. SIZE 5 INCLD. #6 & 7
7	20-066	ORIFICE AIR 6/32" I.D. SIZE 6 INCLD. #6 & 7
8	21-032	CLAMP, HOSE
9	18-084	HOSE, MEDIA 1/2" I.D. (SPECIFY LENGTH)
10	14-302	FITTING-HOSE TO GUN 1/2" HOSE x 3/8" MPT
11	20-041	GUN, STD. COMP. W/CERAMIC NOZZLE (SPECIFY SIZE)
11	20-042	GUN, STD. COMP. W/CARBIDE NOZZLE (SPECIFY SIZE)
12	—	GUN SIZE IS STAMPED ON AIR ORIFICE HEX

LIGHT BOX

M151

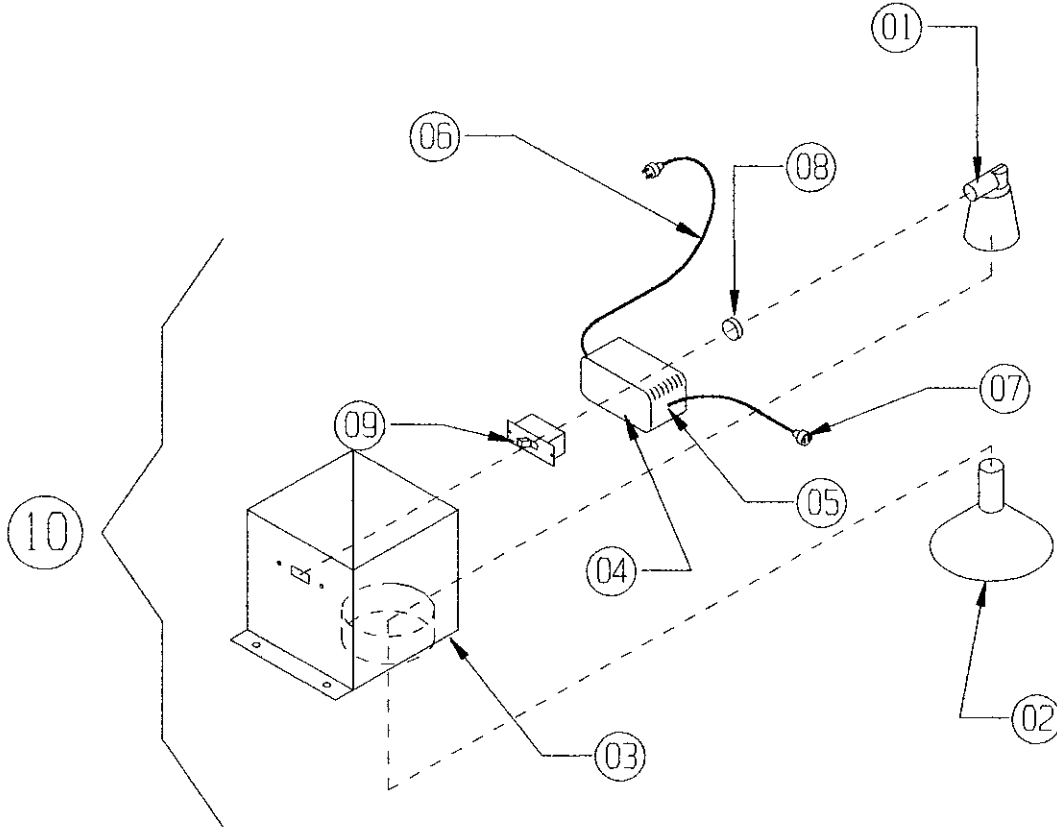

10	1	COMPLETE LIGHT BOX	CONTACT FACTORY
09	1	SWITCH	13-655
08	1	NUT	006201
07	1	CORD WITH FEMALE PLUG	010172
06	1	POWER CORD, 3 WIRE	13-550
05	2	HEYCO CONNECTOR	13-605
04	1	2 x 4 JUNCTION BOX	13-570
03	1	LIGHT BOX ASS'Y.	A747
02	1	LIGHT BULB	010463
01	1	LIGHT FIXTURE, (NO BULB)	010461
ITEM NO.	QTY.	DESCRIPTION	DWG. NO.

ELECTRICAL DIAGRAM

120 VOLT POWER
50/60 HZ
1 PHASE

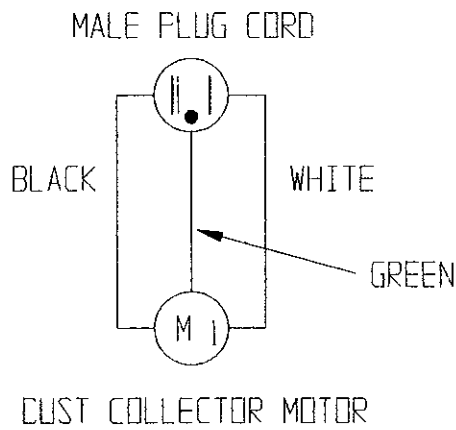
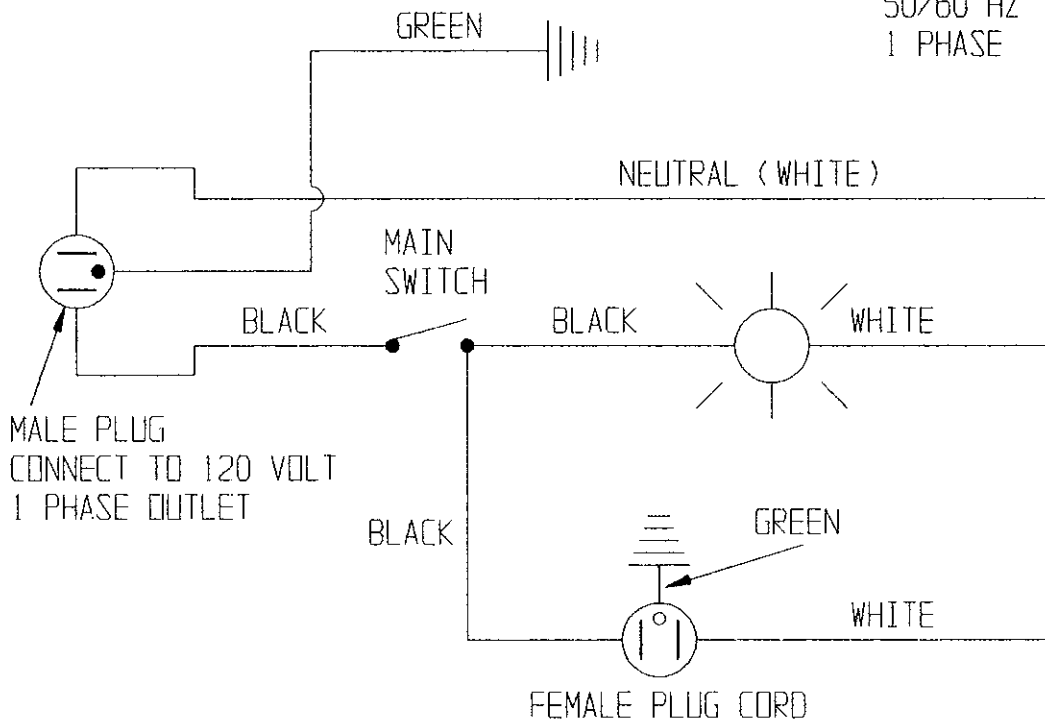

WARRANTY

Larry Hess & Associates, Inc. Warrants to the original purchaser the merchandise sold to be free from defects in material and workmanship under normal use and service for a period of one (1) year. Upon prompt notification by the buyer, to LHA, components that are determined by LHA to be defective will be repaired or replaced at no additional charge, F.O.B. our factory.

Manufacturer shall have the right to inspect prior to replacing all merchandise in question.

This warranty does not apply to parts that are directly involved in the blasting operation. Example: gun, gun parts, viewing window, hose, gloves, etc.

Manufacturer shall not be required to pay any removal or installation charges whatsoever under this warranty.

Manufacturer shall not be liable for prospective profits, special or consequential damages, nor shall any recovery of any kind against manufacturer be greater in amount than the cost of repairs of defects in workmanship.

This warranty does not apply to damage caused by accidents, damage in transit, alterations by unauthorized personnel, abuse or damage by flood, fire, or acts of God, nor by artificially generated electric currents or any other cause whatsoever except defects in material or factory workmanship.

In all cases, defective parts must be returned to Larry Hess & Associates, Inc. before credit is issued.

If genuine BLAST-IT-ALL® replacement parts are not used, the warranty is void.

This warranty is in lieu of all other warranties expressed or implied and releases Larry Hess & Associates, Inc. of all other obligations and liabilities whatsoever. This warranty neither assumes nor authorizes any person to assume any obligation other than those specified by this warranty.

WARNING

DO NOT USE **SAND** SAND WILL CAUSE SILICA DUST, WHICH IS THE CAUSE OF SILICOSIS DISEASE, A CONDITION OF MASSIVE FIBROSIS OF THE LUNGS. ***THIS STATEMENT INDICATES POTENTIAL PERSONNEL HAZARD. FAILURE TO COMPLY WITH THESE INSTRUCTIONS MAY RESULT IN PERSONAL INJURY.***

Distributed By:



2717 Tobey • Indianapolis, IN 46219
(317) 545-0665 • FAX (317) 545-0670 • (800) 800-0665
www.idsblast.com